

Carousel USA

Model 60 HD

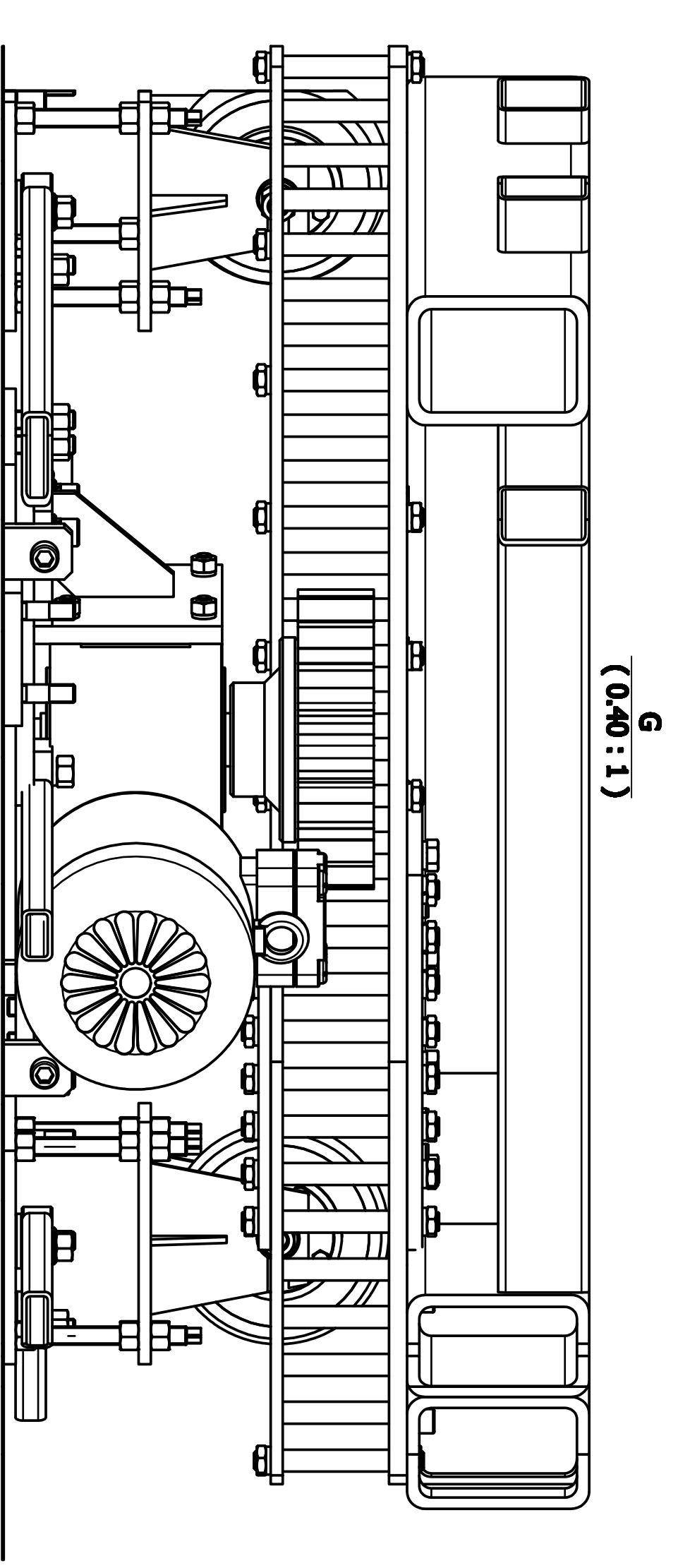
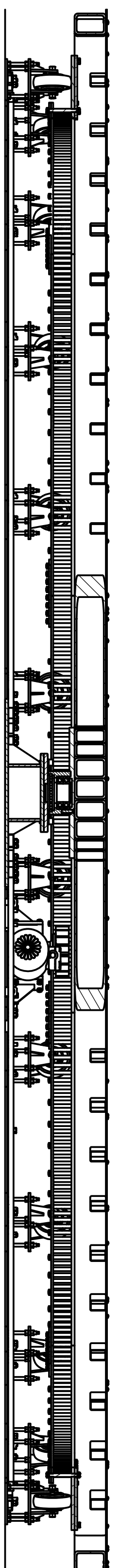

<19.685' Diameter (6 Meters)>

Model 60 HD Specifications:

1. Diameter: 19.685' (6 Meters)
2. Height: 15.75"~17.75".
3. Rotation Speed: 0.1~0.5 RPM.
4. Motor Power: 3 H.P., TEFC, 60:1 Nord Gearbox.
5. Power Required: Single Phase 220V AC, 25 Amps.
6. Rated Load Capability: 48,500 lbs.;12,500 lb point load.
7. Weight of turntable: 9,100 Lbs.
8. Pin-Gear direct drive technology, no friction wheels.